

# Sliding Gate Fitting Guide – Overhead for flat top gates

## Before you start – check list

- Concrete or bolt down track at least twice length of the gap



Note - You will need to supply your own concrete or fixings for the above

- 2-3 gate wheels that insert into the bottom rail of the gate (may already be inserted in factory)



- Overhead support bracket with nylon wheels , you may have 1 or 2 of these or a specially fabricated steel version depending on the gate size.



Art 464 Roller Set

- Note – you will need to supply your own fixings for these. We recommend M10 wall anchors or M10 coach screws, which we can add to your order if you wish. Please ask the office for more info.

-

- Gate catcher

CA COMBI ARIALDO



Art 467 Adjustable Keep

Note – you will need to supply your own fixings for these. We recommend M10 wall anchors or M10 coach screws, which we can add to your order if you wish. Please ask the office for more info.

- Last but not least.. the Gate(s) !
- **Check the dimensions of the gap and the gates! Use the CAD drawing to help you if these have been supplied.**



Optional extra – if this is a large gate made in 2 or more section, we recommend contacting a local engineering workshop to have a 60 x 60mm angle iron the same length as the whole gate when fitted together. **NOT INCLUDED**

## **Tools needed - 2-4 able bodied people needed**

1 x 12mm , 1 x 4mm , 1 x 2mm drill bit, Hammer, Allen keys and grips

2 x saw horses or something to lay gates flat on

Drill , Impact Driver with PZ2

17mm socket for wall anchors or coach screws

Angle grinder to cut excess track

Trench digging equipment (for concrete in track) – we use post hole diggers, pick, narrow shovel and buckets.

## **Phase 1 – installation of the ground track**

Firstly you will need to determine the length of track needed. This can be easily calculated by measuring the opening and doubling.

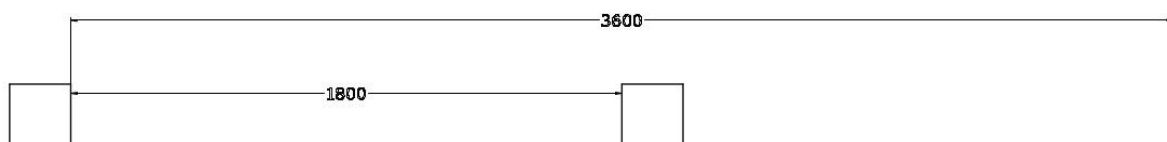

If you have chosen the 'bolt down track' you would need to have prefabricated a level surface which can be made from any material providing it is hardstanding such as paving, concrete, tarmac etc providing you can get strong fixing to hold the track down. TIP - When producing a flat surface, we recommend installing large ducting across the driveway to future proof the area for lighting or gate automation etc.

### **OR**

If you have chosen the concrete in track, you will need to dig a channel deep enough to install the track and any power conduits needed for automation and/or lighting needed. TIP - We recommend installing large ducting across the driveway to future proof the area for lighting or gate automation etc.

**Bolt down track** can be positioned 90mm away from the boundary wall or fence. This is measured from the centre line of the track to the wall/fence. TIP – make sure that 90mm is the minimum distance so the gate does not catch while in operation. Check the wall/fence is plumb and straight. Move or angle the track if needed. Track needs to be fully level for optimum performance.

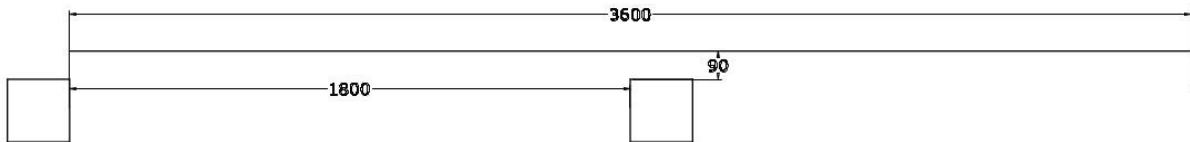

Note – if you need are automating the gate you would need a motor located behind the track, making sure you have conduits from motor to each side of the opening. These conduits can be used for safety and intercom accessories. A 230v power supply will also be required with a local isolation point to the motor pad.

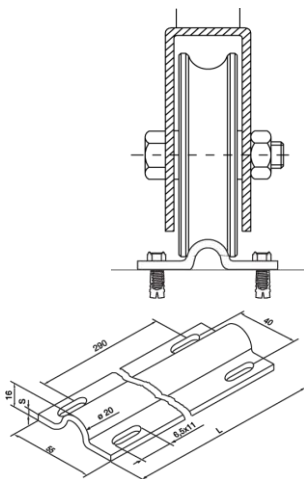
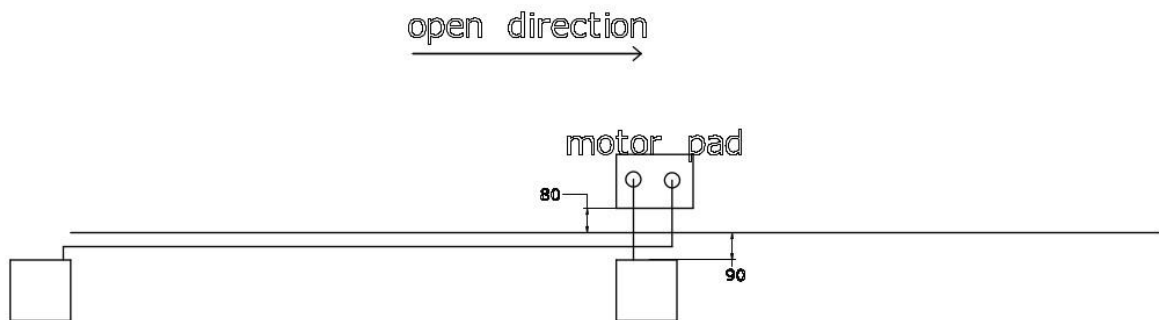

You can now skip to fitting the gate!

**Concrete in Track** needs a trench digging around 150mm wide and 150mm deep. This should be increase in width and depth if the are has heavy duty vehicles regularly or if the ground is very soft such as grassy/muddy areas. You should also dig your foundations for your automation motor pad if you have one.

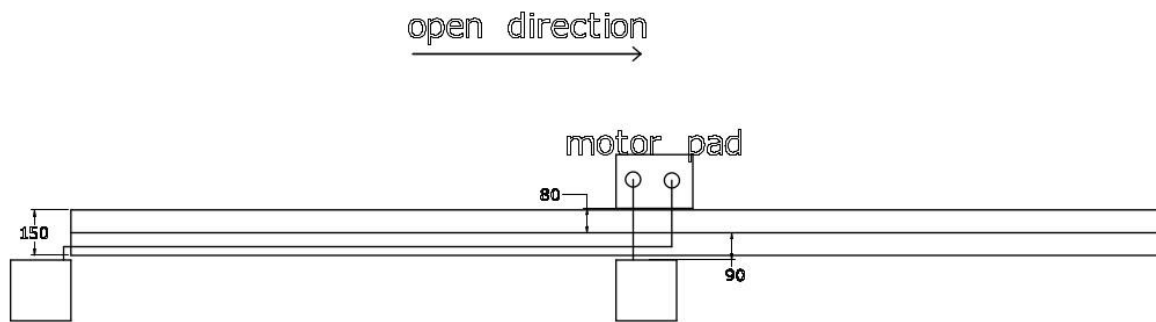

Your motor pad should be 80mm away from the centre line of the track. You also will need conduits from the motor pad to each side of the opening. These conduits can be used for safety and intercom accessories. A 230v power supply will also be required with a local isolation point to the motor pad.

Once you have your trench dug, making sure you have sunk your conduits below the track for protection, you can half fill with concrete and place your track in position. The track should sit above the finished ground level. Note track may look different but same height applies. Track needs to be fully level for optimum performance.

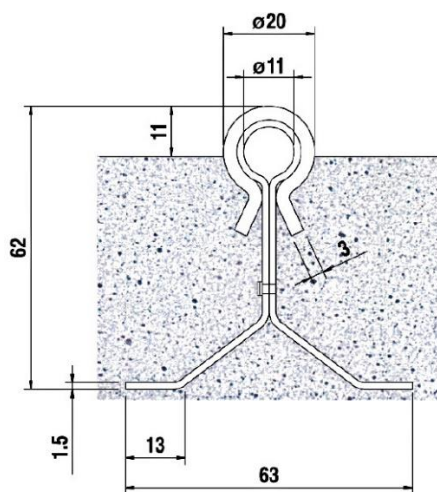

gate!

Once cured after 24-48 hrs. You can now fit the

Now the track has been installed its time to install the gate. You should be careful when lifting as the gates will be heavy. Ensure you have enough lifting personnel or equipment before attempting!

Lie the gate flat on sawhorses or similar. Install the gate wheel(s) into the bottom of the gate approx. 600mm from the edge of each end with 2 large wood screws into predrilled holes. If you have 2 parts, you can offer first gate (larger side first) on to the track and stabilise. Use some chocks to level the gate. Use a spirit level to ensure the gate is level, now mark on the wall where the overhead support will be fitted which should be 25mm above the gate.



Fix this in place. You can now slide the gate into position. Tighten the wheels allowing the gate to move freely open and closed. Find your closed position and then fit your gate catcher. You can now move on to your automation or if this is a manual slider, your done!

**Battens - We offer batten fixing packs with 4 x 30mm caps and M10 through bolts per batten @ £12 each. Please ask to add to order.**

**Step 1:** Cut battens down to desired height.

**Step 2:** Offer the batten up to the brick work and mark which brick to fix into. We recommend 3-4 fixing minimum to ensure strong fix. (make sure the holes line up with a full brick or block rather than mortar as mortar is not strong enough to hang gates on)

**Step 3:** Lay flat on horses, drill 3-4 30mm roughly midway through batten to inset any bolt. Then drill a 12mm hole all the way through the batten in those holes for the bolt to go through..

**Step 3:** Offer back up to wall. Drill M10 holes, fix to wall level (plum) each way. Hammer M10 through bolts into wall (not supplied) and tighten.

**Ground fixing posts - Postcrete available @ £10 per bag**

**Step 1:** Identify post location and check for pipe or cable. Look for services such as gas/electric meter to help. **Or sonar cable finder if available**

**Step 2:** Used concrete breaker to break and loosen ground, then post hole diggers to remove loose dirt.

**Step 3:** repeat until hole is approx. 2.5ft deep. You need a third of post in the ground. Hole should be min 4" bigger than the post.

**Step 4:** Drop post into hole and check correct height and is plumb level.

**Step 5:** Fill hole 1/3 with water and then add postcrete. Repeat as needed to fill hole. Keep post sturdy while hardening checking the level.